

## Charging Pile Specification-CH40

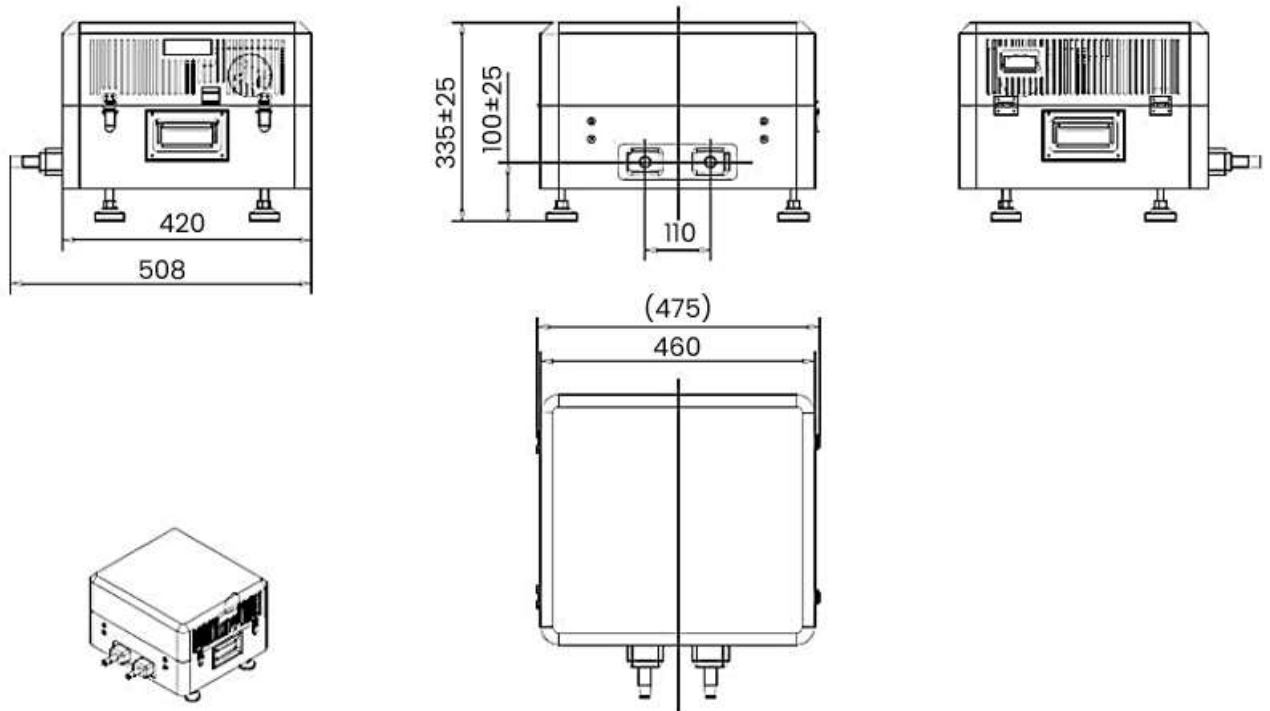

## Contents

	Page
1 Product Overview	3
1.1 Product features	3
2 Product Specification Parameter	3
3 Charging protection features	4
4 Charging instructions	5
5 Safety & electromagnetic compatibility	5
6 Environmental testing requirements	5
7 Use and precautions	6
7.1 Install	6
8 Product appearance and specifications	6
8.1 Appearance structure of charging pile	6
8.2 Charging Pile Size	6
9 Packaging and Transportation	7
9.1 Inner packing	7
9.2 Outer packing	7
9.3 Transportation	7
9.4 Storage	7
10 Charging curve	7



## 1 Product Overview

### 1.1 Product features

This charging system is a floor-standing intelligent charging device developed by our company according to the charging technical requirements of the AGV battery pack. The device uses a programmable controller as the main control unit to provide a convenient and intuitive man-machine exchange operation interface; the main circuit uses a high-frequency switching power supply circuit, which is light in weight, small in size, high in efficiency, and high in precision and stable current. The whole set of equipment is easy to operate/reliable in work/complete protection/high degree of automation. Provide communication interface and contact signal (charging/standby/full and fault) for AGV background monitoring, and interact with the real-time data and working status of the host computer.

After the automatic charging pile is fixed, it can provide: 1~60V, 10~100A fast and voltage and current output

## 2 Product Specification Parameter

Specification	
Name	Charging Pile Specification-CH20
AC input voltage	AC100V~240V 50Hz
Input frequency	50~60Hz
DC output voltage	DC 48V (adjusted according to the AGV body condition)
Maximum output voltage	54.6±0.2 V
DC output current	DC 40A (adjusted according to the AGV body condition)
Maximum output current	40±0.2A
Maximum output power	1500 W
Noise	≤50 dB
Cooling method	Air cooling
Dimensions (L x W x H)	508 x 475 x 360 mm
Weight	30 kg
Installation method	Ground fastening
Power cord length	1.5 m
Charging interface	Bipolar contact type
Maintenance convenience	Flip type

### 3 Charging protection features

No.	Item	Technical Parameters	Remarks
1	Voltage limit protection	The output voltage of the charger will not exceed the set maximum charging voltage of the battery.	
2	Overheat protection	Inside temperature > 65°C, automatic shutdown Transformer temperature > 110°C, automatic shutdown	
3	Current limit protection	The output current of the charger will not exceed the set maximum battery charging current.	Constant current.
4	Short circuit protection	When the output is short-circuited, the charger cannot work normally, the output returns to normal, and the charger can recover by itself.	Connect DC first, then AC
5	Reverse connection protection	When the output line is connected reversely, the charger will not work until the user connects it correctly.	Connect DC first, then AC

#### 4 Charging instructions

No.	Item	Status	Remarks
1	Status	LED1: Red light LED2: Green light	
2	Charging	LED1: Red light LED2: Red light	
3	Full	LED1: Red light LED2: Green light	
4	Output voltage display	Yes	
5	Output current display	Yes	

#### 5 Safety & electromagnetic compatibility

No.	Item		Standard (or test condition)	Remarks
1	Withstand voltage test	input-output	1500Vac/2s ≤5mA	no fault
2	Insulation resistance	input-ground	≥200MΩ@500Vac	
3	Leakage current		< 3.5mA	
4	safety standard		<input checked="" type="checkbox"/> CE <input type="checkbox"/> Ro Hs <input type="checkbox"/> GS <input type="checkbox"/> UL <input type="checkbox"/> CCC <input type="checkbox"/> SAA <input type="checkbox"/> PSE <input type="checkbox"/> KC	
5	Electromagnetic compatibility		EN55014-2:1997+A1:2001+A2:2008	
6	Low voltage test LVD		EN60335-1:2002+EN60335-2-29:2002	

#### Notes

The protection device (fuse) caused by the signal is damaged, and the entire device can only work normally after replacing the protection device and resetting the operating parameters, but the equipment due to mechanical damage and equipment failure cannot.

#### 6 Environmental testing requirements

No.	Item	Technical Parameters	Remarks
1	Maximum ambient working temperature	+40°C	normal performance
2	Lowest ambient working temperature	-10°C	normal performance
3	Maximum storage temperature	+70°C	After 2 hours of returning to normal temperature, the charger can work normally.
4	The Minimum storage temperature	-20°C	The charger can work normally after returning to normal temperature for 2 hours.

## 7 Use and precautions

### 7.1 Install

- 7.1.1 This charging system is adapted to the series battery packs produced by our company
- 7.1.2 The charging system is connected to 220V AC power supply. When the power indicator LED1 is red/LED2 is red, it means charging starts
- 7.1.3 When the LED2 light turns from red to green, it means that the battery is fully charged
- 7.1.4 The charging system display screen can display the output voltage and power, and the display interface can be switched through the V/A switch
- 7.1.5 The charging system should be stored and used in a dry/ventilated/dust-free environment, pay attention to moisture and waterproof
- 7.1.6 This charging system will generate heat when it is working, so it is strictly forbidden to cover and block the exhaust vent
- 7.1.7 Pay attention to the correct connection of the positive and negative poles. If the positive and negative poles are incorrectly connected, it will cause a short circuit alarm and safety risks
- 7.1.8 Please avoid operation by non-related personnel or close to the charging pile area.

## 8 Product appearance and specifications

### 8.1 Appearance structure of charging pile



Material: all stainless-steel shell

Color: Default is milky white

### 8.2 Charging Pile Size

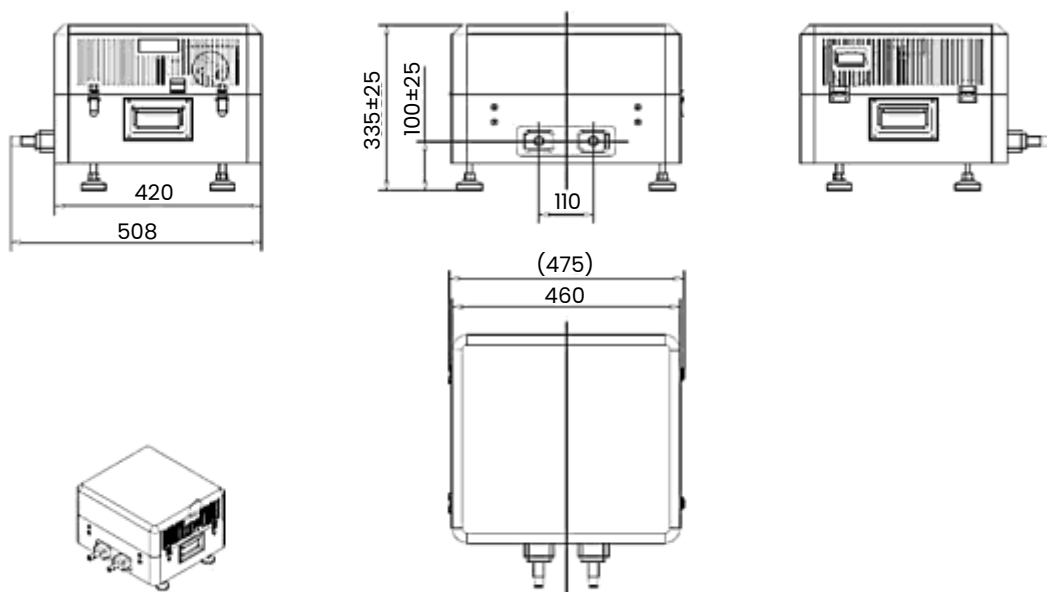

## 9 Packaging and Transportation

### 9.1 Inner packing

Shell with the original factory envelope, filling material for foam, PE film, etc.

### 9.2 Outer packing

**Packing label** product name, product model, instruction and packing list/delivery list.

**Material requirements** recommended wooden case, to prevent extrusion and scraping products.

### 9.3 Transportation

Suitable for truck loading, should be placed in a cool and dry place, please be careful when loading and unloading.

### 9.4 Storage

When the product is not in use, it should be placed in the packaging. The limit temperature of the warehouse should be  $-20\sim 70^{\circ}\text{C}$ , the normal temperature should be  $-20\sim 50^{\circ}\text{C}$ , the relative humidity should be 5~90%, and the surrounding environment should be free of harmful gases, flammables, explosives, corrosive chemicals and strong mechanical vibration, shock and magnetic field influence. It must be placed at least 20cm high from the ground and 50cm away from walls, heat sources, and vents. The charging equipment can be stored for two years under this storage condition, and it must be tested again after two years. The charging equipment must be energized once every three months, and the energizing time should be no less than 0.5 hours.

## 10 Charging curve

During the initial stage of charging, the system controls the current to remain constant (CC). When the battery voltage increases and reaches the specified value, the system switches to constant voltage control (CV). Once the current decreases to the preset level, the system automatically stops charging.

