

# Autonomous Forklift R500F-LH05

LiDAR SLAM Navigation+500KG Payload

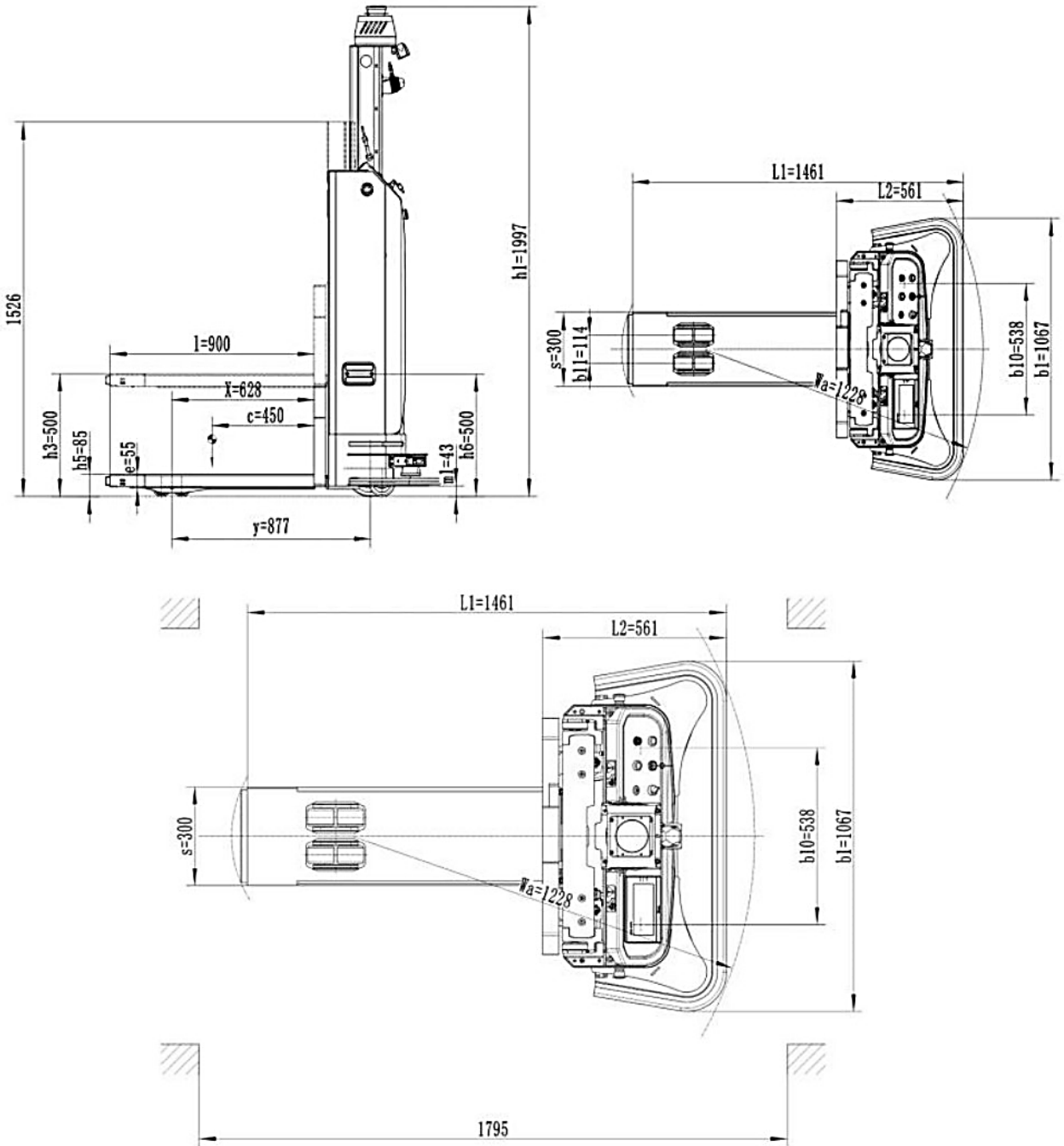

## Dimension



<b>Specification</b>	
<b>Basic parameters</b>	
Name	Autonomous Forklift R500F-LH05
Navigation mode	LiDAR SLAM
Drive mode	Steering Wheel Drive
Dimension (L x W x H)	1484 x 1067 x 1997 mm
Weight (with batteries)	680 Kg (±10 Kg)
Maximum payload	500 kg
Chassis ground clearance	31.5 mm
Standard lifting height	500 mm
Fork dimensions (L x W)	900 x 300 mm/Customized
Pallet type	Tote dolly / shelf
Network	Ethernet / Wi-Fi 802.11 a/b/g/n/ac
Ambient temperature and humidity range	Temperature: 0~50°C / Humidity: 10~90%, No compression condensation
IP rating [1]	IP20
<b>Performance Parameters</b>	
Possibility (slope/step/gap) [2]	≤5 %/2 mm/5 mm
Navigation position accuracy [3]	±10 mm
Navigation angle accuracy [3]	±1°
Operation speed (Adjustable)	≤1.4 m/s
<b>Battery Parameters</b>	
Battery specifications	DC48V/40Ah (Lithium iron phosphate)
Endurance time	8 hr.
Charging time (10~80%)	≤2 hr.
Charging mode	Manual/Automatic
Battery cycle times	1500 cycles, capacity≥80%
<b>Safety Parameters</b>	
Emergency stop button	✓
Sound and light indicator	✓
Braking distance (1 m/s / 1.5 m/s)	≤30cm/ ≤50cm
360° laser protection	✓
Bumper strip	✓
Fork height protection	✓
<b>Functions Parameters</b>	
Basic function [4]	✓
Wi-Fi Roaming	✓
3D obstacle avoidance	Optional
Pallet recognition	Optional
HMI display	✓

[1] Designed for indoor transport, not recommended for outdoor environments

[2] Road surface is smooth, clean and without significant undulations. Slope5%= arctan (0.05) ≈ 2.8°. The robot may not stop or turn at ramps, steps, or gaps, but may only pass quickly perpendicular to them.

[3] Navigation accuracy usually refers to the repeated accuracy of the robot navigation to the target site. When the environment scanned by the robot LiDAR is relatively stable (change rate <30%), the repeated accuracy of the robot navigation from the fixed direction to the target site can reach the expected value. When the robot runs along the virtual path, it will try to fit the path, but it does not guarantee repeatability. That is, the robot can guarantee the accuracy of the point, without guaranteeing the accuracy of the navigation path. The minimum site spacing supported by the robot is 1cm.

[4] The basic functions include map editing, model editing, positioning and navigation, basic motion model (differential), API interface, etc.